

## 1. Transfer the paper roll to the roll:

- Hold the reel in your left hand and place the roll on the reel so that the label is transferred from below and the left end of the roll is against the side of the reel.
- Slide the reel guide on the right side of the reel and press the guide down against the label roll without leaving a gap between the roll and the reel.
- To ensure proper label printing, the paper roll must be attached to both sides of the paper roll without any gap.

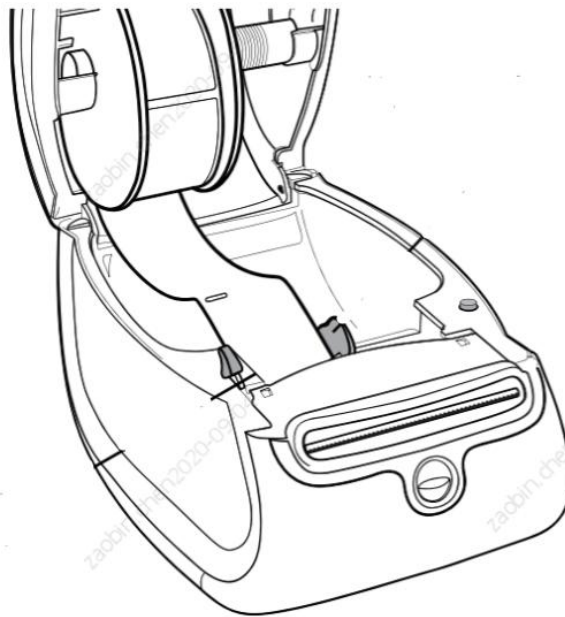
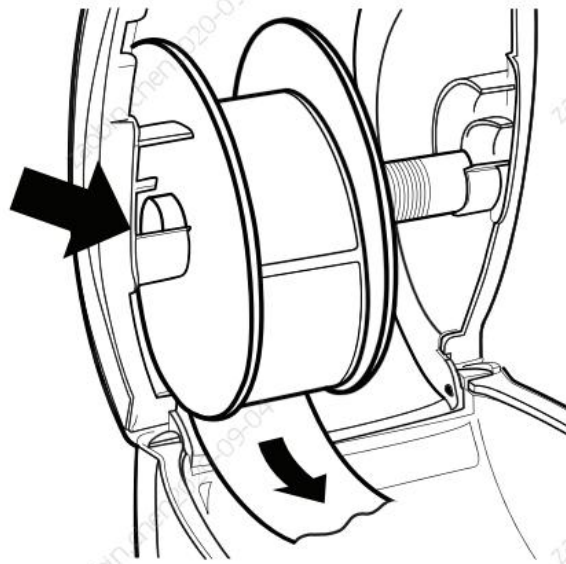

2. Insert the label roll into the paper bin and make the label protrude from below

3. Align the left end of the label with the left end of the paper feed slot, and insert the label into the slot

- The printer will automatically feed the label and stop after the first label is printed.
- If the printer does not automatically feed, press the page feed button to eject an incomplete label.

4. Slide the label guide to the left until the label guide is aligned with the right end of the label.

Ensure that the label guide does not jam the label.

5. Close the printer paper bin

Use editing software to edit and print